

GRAND CANYON

PAR36 Directional Light



DESCRIPTION

The Brilliance Grand Canyon Directional Light comes complete with a built-in glare shield, Brilliance Metal Works signature adjusting system with 22 points of articulation in 10-degree increments, ABS mounting stake, and Lighting Shrink professional crimp and heat shrink cable connector.

LAMP: PAR36, 4W, 2700K, 30°

FINISH: Machined copper, brass, or blackened brass

USE: Uplighting, grazing, backlighting, and wall washing (when used with 120° lamps only)



Part Number: **GRAND CANYON DL-PAR36-CU-(NL)**

BR-(NL)

BR-BLK-(NL)

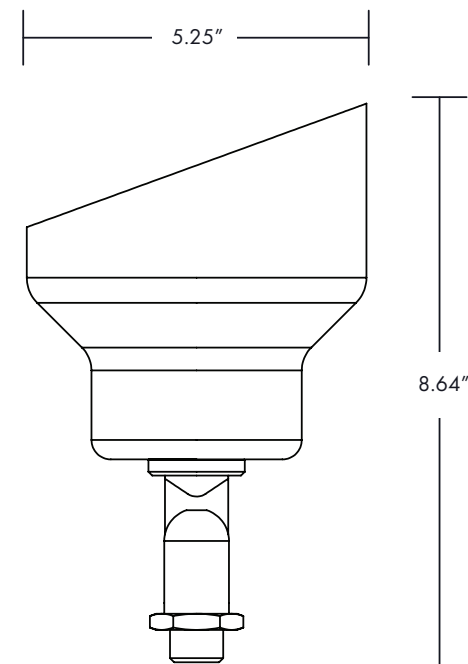

GRAND CANYON DL-PAR36-CU

INSTALLING THE LAMP

1. Loosen the terminal screws on the PAR36 lamp.
2. Slide the "U" terminal connector under each terminal screw and tighten.
3. Set the edge of the lamp onto the first 2 stainless steel flex fingers.
Pull back on the remaining flex finger and snap the lamp into the fixture.

INSTALLING THE GROUND STAKE

1. Dig a hole in the ground approximately 4" wide by 10" deep. A rubber mallet may be used to drive the stake into the ground when working with soft soil.
2. Lay the power cable from the fixture into the slotted relief on the stake.
3. Screw the fixture into the stake.
4. Use a level to assure the top of the stake is level with the ground.

ADJUSTING THE FIXTURE

1. Turn the knuckle counter-clockwise to loosen the knuckle.
2. Rotate the fixture vertically to the desired position.
3. Turn the knuckle clockwise to hold it in the desired position.

Adjusting the fixture allows for dark sky ordinances applications.