



**PROFESSIONAL
OUTDOOR LIGHTING**

Type:

Model:

Project:

SPECIFICATION SHEET

MODEL 5223 Landscape Series • Step & Brick Lights

FIXTURE SPECIFICATIONS:

HOUSING:

Injection-molded, glass-reinforced Ryton® R-4 composite for strength & high UV stability – warranted for ten years against corrosion. The cover plate is fitted to the recessed box with a silicone o-ring gasket – providing a superior weather-tight seal.

FINISH:

Durable powder coat finish available in Black, Dark Bronze, Granite, White, Architectural Brick, Light Bronze, Special Bronze, Glossy Gray, Rust, Hunter Green, Weathered Bronze, Weathered Iron, Graphite Metallic, Verde, Pewter, Mocha and Olde Finish. Custom Powder coat finishes available on request.

SOCKET/LAMP HOLDER:

Top grade ceramic socket with nickel contacts, stainless steel springs, & Teflon-jacketed wire leads.

LENS:

Frosted, tempered, shock & heat-resistant, soda lime glass lens.

LAMP TYPE:

MR-16 Halogen – 35W maximum. LN-20 BAB (20W) Standard.

MOUNTING:

Recessed mounting box has two 1/2" NPT inlets. Optional concrete mounting kit available, please see accessories column on fixture ordering information.

FASTENERS/INSERTS:

All fasteners are stainless steel with brass inserts.

WIRING:

Provided with a three-foot pigtail of 18-2 direct-burial cable & underground connectors for a secure connection to the supply cable.

CERTIFICATION:

UL Listed to U.S. & Canadian safety standards for low voltage landscape luminaires (UL 1838). The maximum wattages allowed by Underwriters Laboratories (UL) for the U.S. & Canadian markets may vary. Maximum wattages specified are Underwriters Laboratories U.S. standard. Please contact Vista for any questions about the maximum wattages allowed by UL Canadian standards.

All Vista luminaires are [MADE IN THE U.S.A.](#)

This fixture is also available as a LED luminaire. Please refer to LED Specification Sheet - 5223-LED.

DIMENSIONS:

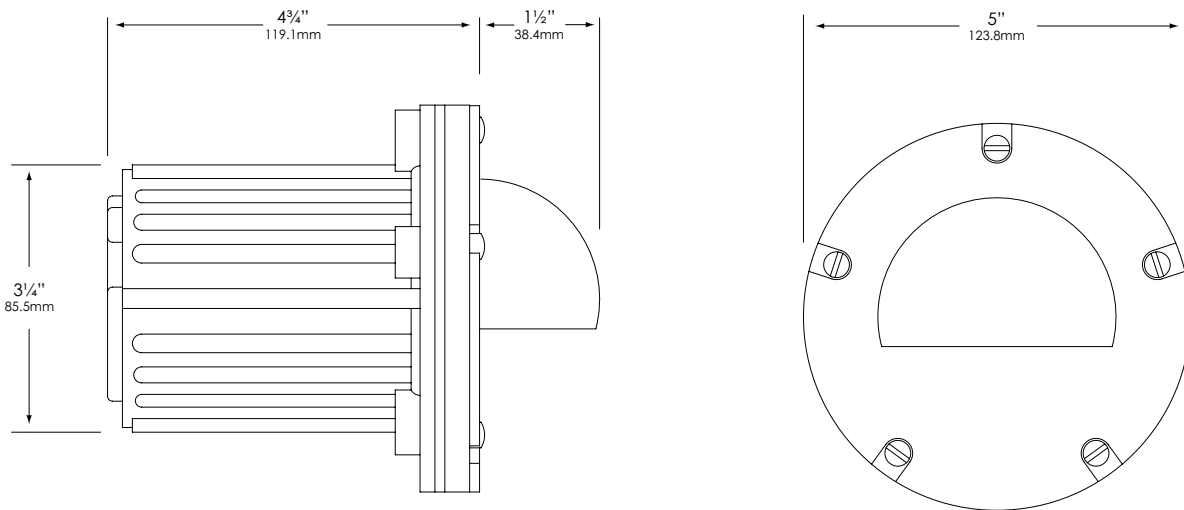

Vista Professional Outdoor Lighting reserves the right to modify the design and/or construction of the fixture shown without further notification.



SPECIFICATION SHEET

MODEL 5223 Landscape Series • Step & Brick Lights

FIXTURE ORDERING INFORMATION

TO ORDER FIXTURE: Select appropriate choice from each column as in the following example.

EXAMPLE: SL-5223-B-BAB

MOUNTING	MODEL	FINISH	LAMP	ACCESSORIES
SL- Step light	5223	Standard	BAB - 20W	JBCP-150 - Concrete Mounting Kit
		B - Black	LN-20 BAB Standard Halogen	
		B - Architectural Bronze		
		DZ - Dark Bronze		
		GT - Granite		
		W - White		
		Premium	4.5-W-36 - 4.5W	
		BR - Architectural Brick	LN16-4.5-W-A-36-LED	
LZ - Light Bronze	Standard LED			
SB - Special Bronze	(Please see lamp order code column in lamp guide of Vista product catalog)			
GG - Glossy Gray				
R - Rust				
HG - Hunter Green				
WB - Weathered Bronze				
WI - Weathered Iron				
GM - Graphite Metallic				
Hand Finished				
G - Verde				
P - Pewter				
M - Mocha				
OF - Olde Finish				

Fixtures shipped with standard lamp, unless otherwise specified.